

## Dual T1/E1 Line Interface

### Features

- Dual T1/E1 Line Interface Optimized for Multiplexer Applications
- Low Power Consumption (Typically 220mW per Line Interface)
- Transmit Driver Performance Monitors
- Jitter Attenuation in the Transmit Path
- Matched Impedance Transmit Drivers
- Supports JTAG Boundary Scan
- Hardware Mode Derivative of the CS61584

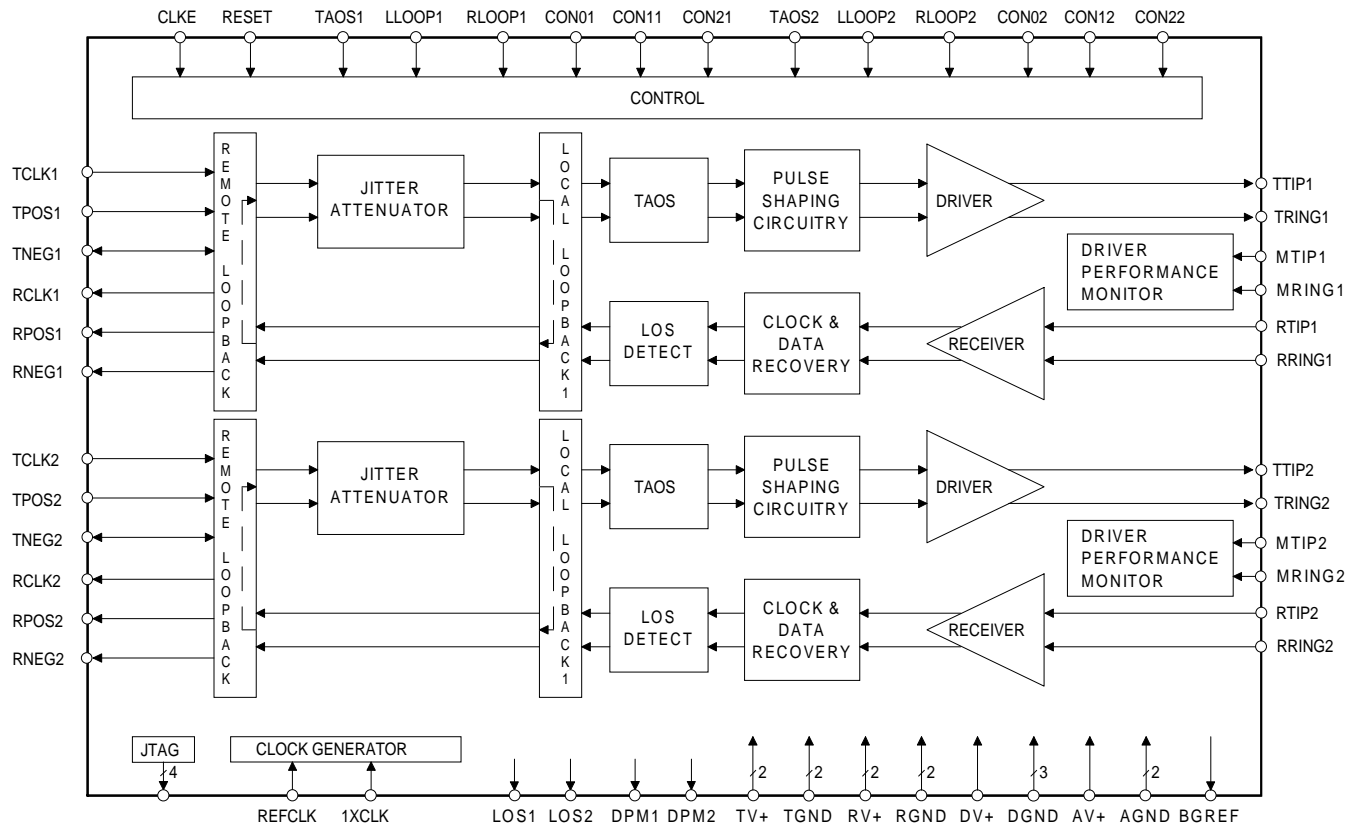
### General Description

The CS61582 is a dual line interface optimized for highly-integrated T1/E1 asynchronous or synchronous multiplexer applications such as SONET and SDH. Each channel features individual control and status pins which eliminates the need for external microprocessor support. The matched impedance drivers reduce power consumption and provide substantial return loss to insure superior T1/E1 pulse quality.

The CS61582 provides two transmitter driver performance monitor circuits and JTAG boundary scan to enhance system testability and reliability. The CS61582 is a 5 volt device that is a hardware mode derivative of the CS61584.

### ORDERING INFORMATION

CS61582-IQ5, 64-pin TQFP, -40 to +85 °C



**Table of Contents**

Block Diagram .....	1
Specifications	
Absolute Maximum Ratings.....	3
Recommended Operating Conditions.....	3
Digital Characteristics.....	4
Analog Specifications	
Receiver .....	4
Jitter Attenuator .....	4
Transmitter .....	5
Switching Characteristics	
T1 Clock/Data.....	6
E1 Clock/Data.....	6
JTAG.....	8
General Description	
Overview.....	9
Transmitter .....	9
Receiver .....	10
Jitter Attenuator .....	11
Reference Clock .....	11
Power-Up Reset .....	12
Line Control and Monitoring .....	12
Driver Performance Monitor .....	12
Loss of Signal.....	12
Transmit All Ones .....	12
Local Loopback .....	12
Remote Loopback.....	13
Reset Pin.....	13
JTAG Boundary Scan.....	13
Pin Description .....	21
Physical Dimensions.....	25
Applications .....	26

## ABSOLUTE MAXIMUM RATINGS

Parameter	Symbol	Min	Max	Units
DC Supply (TV+1, TV+2, RV+1, RV+2, AV+, DV+) (Note 1)		-	6.0	V
Input Voltage (Any Pin)	$V_{in}$	RGND - 0.3	(RV+) + 0.3	V
Input Current (Any Pin) (Note 2)	$I_{in}$	-10	10	mA
Ambient Operating Temperature	$T_A$	-40	85	°C
Storage Temperature	$T_{stg}$	-65	150	°C

WARNING: Operations at or beyond these limits may result in permanent damage to the device.  
Normal operation is not guaranteed at these extremes.

Notes: 1. Referenced to RGND1, RGND2, TGND1, TGND2, AGND, DGND at 0V.  
2. Transient currents of up to 100 mA will not cause SCR latch-up.

## RECOMMENDED OPERATING CONDITIONS

Parameter	Symbol	Min	Typ	Max	Units
DC Supply (TV+1, TV+2, RV+1, RV+2, AV+, DV+) (Note 3)		4.75	5.0	5.25	V
Ambient Operating Temperature	$T_A$	-40	25	85	°C
Power Consumption (Each Channel)	T1 (Notes 4 and 5)	-	310	-	mW
	T1 (Notes 4 and 6)	-	220	-	mW
	E1, 75Ω (Notes 4 and 5)	-	275	-	mW
	E1, 120Ω (Notes 4 and 5)	-	275	-	mW
REFCLK Frequency	T1 1XCLK = 1	1.544 - 100 ppm	1.544	1.544 + 100 ppm	MHz
	T1 1XCLK = 0	12.352 - 100 ppm	12.352	12.352 + 100 ppm	MHz
	E1 1XCLK = 1	2.048 - 100 ppm	2.048	2.048 + 100 ppm	MHz
	E1 1XCLK = 0	16.384 - 100 ppm	16.384	16.384 + 100 ppm	MHz

Notes: 3. TV+1, TV+2, AV+, DV+, RV+1, RV+2 should be connected together. TGND1, TGND2, RGND1, RGND2, DGND1, DGND2, DGND3 should be connected together.  
4. Power consumption while driving line load over operating temperature range. Includes IC and load. Digital input levels are within 10% of the supply rails and digital outputs are driving a 50 pF capacitive load.  
5. Assumes 100% ones density and maximum line length at 5.25V.  
6. Assumes 50% ones density and 300ft. line length at 5.0V.

**DIGITAL CHARACTERISTICS** ( $T_A = -40$  to  $85$  °C; power supply pins within  $\pm 5\%$  of nominal)

Parameter	Symbol	Min	Typ	Max	Units
High-Level Input Voltage (Note 7)	$V_{IH}$	(DV+)-0.5	-	-	V
Low-Level Input Voltage (Note 7)	$V_{IL}$	-	-	0.5	V
High-Level Output Voltage (Digital pins) $I_{OUT} = -40$ $\mu$ A (Note 8)	$V_{OH}$	(DV+)-0.3	-	-	V
Low-Level Output Voltage (Digital pins) $I_{OUT} = 1.6$ mA (Note 8)	$V_{OL}$	-	-	0.3	V
Input Leakage Current (Digital pins except J-TMS, and J-TDI)		-	-	$\pm 10$	$\mu$ A

Notes: 7. Digital inputs are designed for CMOS logic levels.

8. Digital outputs are TTL compatible and drive CMOS levels into a CMOS load.

**ANALOG SPECIFICATIONS** ( $T_A = -40$  to  $85$  °C; power supply pins within  $\pm 5\%$  of nominal)

Parameter	Min	Typ	Max	Units
<b>Receiver</b>				
RTIP/RRING Differential Input Impedance	-	20k	-	$\Omega$
Sensitivity Below DSX-1 (0 dB = 2.4 V)	-13.6	-	-	dB
Loss of Signal Threshold	-	0.3	-	V
Data Decision Threshold T1, DSX-1 (Note 9)	60	65	70	% of Peak
E1 (Note 10)	55	-	75	
(Note 11)	45	50	55	
(Note 12)	40	-	60	
Allowable Consecutive Zeros before LOS	160	175	190	bits
Receiver Input Jitter Tolerance (DSX-1, E1)				
10 Hz and below (Note 13)	300	-	-	UI
2 kHz	6.0	-	-	UI
10 kHz - 100 kHz	0.4	-	-	UI
Receiver Return Loss				
51 kHz - 102 kHz (Notes 14, 21, and 22)	12	-	-	dB
102 kHz - 2.048 MHz	18	-	-	dB
2.048 MHz - 3.072 MHz	14	-	-	dB
<b>Jitter Attenuator</b>				
Jitter Attenuation Curve T1 (Notes 14 and 15)	-	4	-	Hz
Corner Frequency E1	-	5.5	-	Hz
Attenuation at 10 kHz Jitter Frequency (Notes 14 and 15)	-	60	-	dB
Attenuator Input Jitter Tolerance (Before Onset of FIFO Overflow or Underflow Protection) (Note 14)	28	43	-	$UI_{pk-pk}$

Notes: 9. For input amplitude of 1.2  $V_{pk}$  to 4.14  $V_{pk}$

10. For input amplitude of 0.5  $V_{pk}$  to 1.2  $V_{pk}$ , and 4.14  $V_{pk}$  to 5.0  $V_{pk}$

11. For input amplitude of 1.07  $V_{pk}$  to 4.14  $V_{pk}$ ,

12. For input amplitude of 4.14  $V_{pk}$  to 5.0  $V_{pk}$ ,

13. Jitter tolerance increases at lower frequencies. Refer to the Receiver section.

14. Not production tested. Parameters guaranteed by design and characterization.

15. Attenuation measured with sinusoidal input jitter equal to 3/4 of measured jitter tolerance.

Circuit attenuates jitter at 20 dB/decade above the corner frequency. Output jitter can increase significantly when more than 28 UI's are input to the attenuator. Refer to the Jitter Attenuator section.

**ANALOG SPECIFICATIONS** ( $T_A = -40$  to  $85$  °C; power supply pins within  $\pm 5\%$  of nominal)

Parameter		Min	Typ	Max	Units
<b>Transmitter</b>					
AMI Output Pulse Amplitudes	(Note 16)				
E1, 75 $\Omega$	(Note 17)	2.14	2.37	2.6	V
E1, 120 $\Omega$	(Note 18)	2.7	3.0	3.3	V
T1, DSX-1	(Note 19)	2.4	3.0	3.6	V
Recommended Transmitter Output Load	(Note 16)				
T1		-	76.6	-	$\Omega$
E1, 75 $\Omega$		-	57.4	-	$\Omega$
E1, 120 $\Omega$		-	90.6	-	$\Omega$
Jitter Added During Remote Loopback					
10 Hz - 8 kHz		-	0.005	-	UI
8 kHz - 40 kHz		-	0.008	-	UI
10 Hz - 40 kHz		-	0.010	-	UI
Broad Band	(Note 20)	-	0.015	-	UI
Power in 2 kHz band about 772 kHz	(Notes 14 and 21) (DSX-1 only)	12.6	15	17.9	dBm
Power in 2 kHz band about 1.544 MHz (referenced to power in 2 kHz band at 772 kHz)	(Notes 14 and 21) (DSX-1 only)	-29	-38	-	dB
Positive to Negative Pulse Imbalance	(Notes 14 and 21)				
T1, DSX-1		-	0.2	0.5	dB
E1, amplitude at center of pulse interval		-5	-	+5	%
E1, width at 50% of nominal amplitude		-5	-	+5	%
Transmitter Return Loss	(Notes 14, 21, and 22)				
51 kHz - 102 kHz		18	25	-	dB
102 kHz - 2.048 MHz		14	18	-	dB
2.048 MHz - 3.072 MHz		10	12	-	dB
E1 Short Circuit Current	(Note 23)	-	-	50	mA <sub>rms</sub>
E1 and DSX-1 Output Pulse Rise/Fall Times	(Note 24)	-	25	-	ns
E1 Pulse Width (at 50% of peak amplitude)		-	244	-	ns
E1 Pulse Amplitude for a space	E1, 75 $\Omega$ E1, 120 $\Omega$	-0.237 -0.3	- -	0.237 0.3	V V

- Notes: 16. Using a transformer that meets the specifications in the Applications section.  
 17. Measured across 75  $\Omega$  at the output of the transmit transformer for CON2/1/0 = 0/0/0.  
 18. Measured across 120  $\Omega$  at the output of the transmit transformer for CON2/1/0 = 0/0/1.  
 19. Measured at the DSX-1 cross-connect for line length settings CON2/1/0 = 0/1/0, 0/1/1, 1/0/0, 1/0/1, and 1/1/0 after the appropriate length of #22 ABAM cable specified in Table 1.  
 20. Input signal to RTIP/RRING is jitter free. Values will reduce slightly if jitter free clock is input to TCLK.  
 21. Typical performance using the line interface circuitry recommended in the Applications section.  
 22. Return loss =  $20 \log_{10} \text{ABS}((z_1+z_0)/(z_1-z_0))$  where  $z_1$ =impedance of the transmitter or receiver, and  $z_0$ =cable impedance.  
 23. Transformer secondary shorted with 0.5  $\Omega$  resistor during the transmission of 100% ones.  
 24. At transformer secondary and measured from 10% to 90% of amplitude.

**SWITCHING CHARACTERISTICS - T1 CLOCK/DATA** ( $T_A = -40$  to  $85$  °C; power supply pins within  $\pm 5\%$  of nominal; Inputs: Logic 0 = 0V, Logic 1 = DV+) (See Figures 1, 2, and 3)

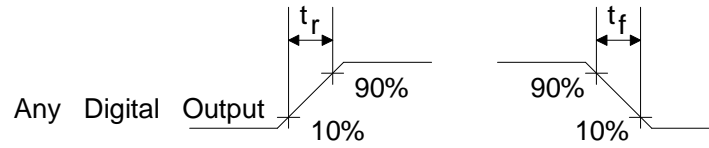
Parameter	Symbol	Min	Typ	Max	Units
TCLK Frequency (Note 25)	$f_{clk}$	-	1.544	-	MHz
TCLK Duty Cycle	$t_{pwh2}/t_{pw2}$	30	50	70	%
RCLK Duty Cycle	$t_{pwh1}/t_{pw1}$	45	50	55	%
Rise Time (All Digital Outputs) (Note 26)	$t_r$	-	-	65	ns
Fall Time (All Digital Outputs) (Note 26)	$t_f$	-	-	65	ns
RPOS/RNEG to RCLK Rising Setup Time	$t_{su1}$	-	274	-	ns
RCLK Rising to RPOS/RNEG Hold Time	$t_{h1}$	-	274	-	ns
TPOS/TNEG to TCLK Falling Setup Time	$t_{su2}$	25	-	-	ns
TCLK Falling to TPOS/TNEG Hold Time	$t_{h2}$	25	-	-	ns

Notes: 25. The maximum burst rate of a gapped TCLK input clock is 8.192 MHz. The maximum gap size that can be tolerated on TCLK is 28 Ulp-p.

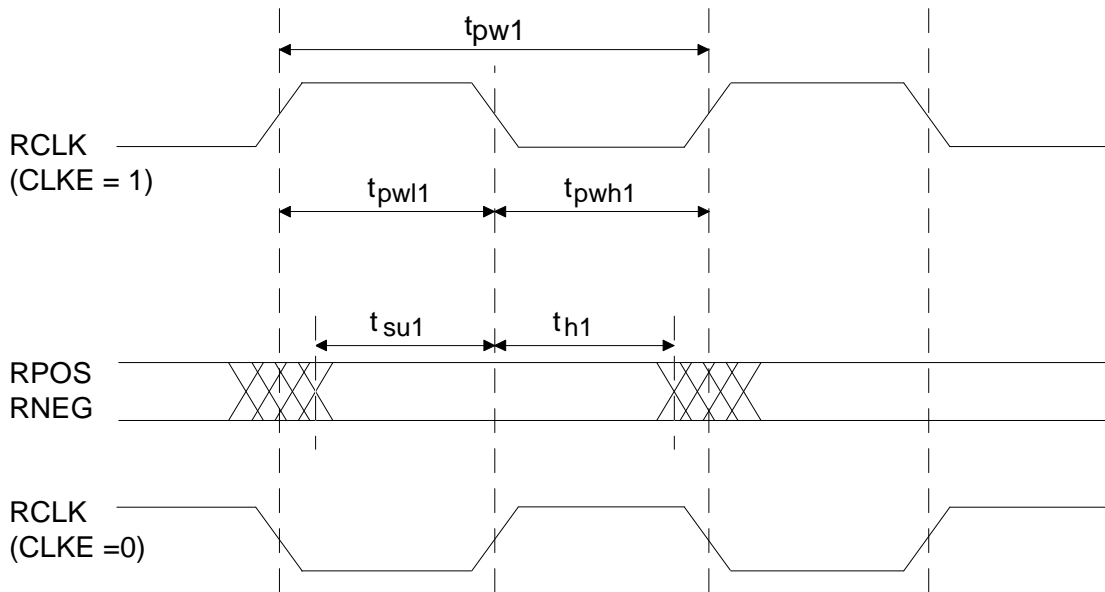
26. At max load of 50 pF.

**SWITCHING CHARACTERISTICS - E1 CLOCK/DATA** ( $T_A = -40$  to  $85$  °C; power supply pins within  $\pm 5\%$  of nominal; Inputs: Logic 0 = 0V, Logic 1 = DV+) (See Figures 1, 2, and 3)

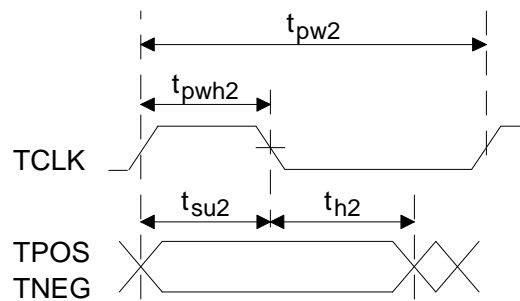
Parameter	Symbol	Min	Typ	Max	Units
TCLK Frequency (Note 25)	$f_{clk}$	-	2.048	-	MHz
TCLK Duty Cycle	$t_{pwh2}/t_{pw2}$	30	50	70	%
RCLK Duty Cycle	$t_{pwh1}/t_{pw1}$	45	50	55	%
Rise Time (All Digital Outputs) (Note 26)	$t_r$	-	-	65	ns
Fall Time (All Digital Outputs) (Note 26)	$t_f$	-	-	65	ns
RPOS/RNEG to RCLK Rising Setup Time	$t_{su1}$	-	194	-	ns
RCLK Rising to RPOS/RNEG Hold Time	$t_{h1}$	-	194	-	ns
TPOS/TNEG to TCLK Falling Setup Time	$t_{su2}$	25	-	-	ns
TCLK Falling to TPOS/TNEG Hold Time	$t_{h2}$	25	-	-	ns



**Figure 1. Signal Rise and Fall Characteristics**



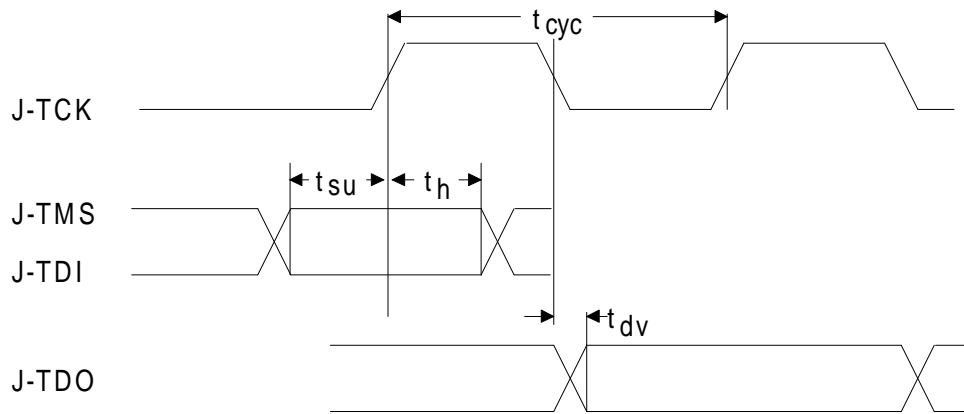
**Figure 2. Recovered Clock and Data Switching Characteristics**



**Figure 3. Transmit Clock and Data Switching Characteristics**

**SWITCHING CHARACTERISTICS - JTAG** ( $T_A = -40^\circ$  to  $85^\circ$  C;  
 TV+, RV+ = nominal  $\pm 0.3V$ ; Inputs: Logic 0 = 0V, Logic 1 = RV+) (See Figure 4)

Parameter	Symbol	Min	Typ	Max	Units
Cycle Time	$t_{cyc}$	200	-	-	ns
J-TMS/J-TDI to J-TCK rising setup time	$t_{su}$	50	-	-	ns
J-TCK rising to J-TMS/J-TDI hold time	$t_h$	50	-	-	ns
J-TCK falling to J-TDO valid	$t_{dv}$	-	-	50	ns



**Figure 4. JAG Switching Characteristics**



## OVERVIEW

The CS61582 is a dual line interface optimized for highly-integrated T1/E1 asynchronous or synchronous multiplexer applications such as SONET or SDH. One board design can support all T1/E1 short-haul modes by only changing component values in the receive and transmit paths (if REFCLK and TCLK are externally tied together).

All control of the device is achieved via external pins, eliminating the need for microprocessor support. The following pin control options are available on a per channel basis: line length selection, transmit all ones, local loopback, and remote loopback.

The line driver generates waveforms compatible with E1 (CCITT G.703), T1 short haul (DSX-1) and T1 FCC Part 68 Option A (DS1). A single transformer turns ratio is used for all waveform types. The driver internally matches the impedance of the load, providing excellent return loss to insure superior T1/E1 pulse quality. An additional benefit of the internal impedance matching is a 50 percent reduction in power consumption compared to implementing return loss using external resistors that causes the transmitter to drive the equivalent of two line loads.

The line receiver contains all the necessary clock and data recovery circuits.

The jitter attenuator meets AT&T 62411 requirements when using a 1X or 8X reference clock supplied by either a crystal oscillator or external reference at the REFCLK input pin.

## TRANSMITTER

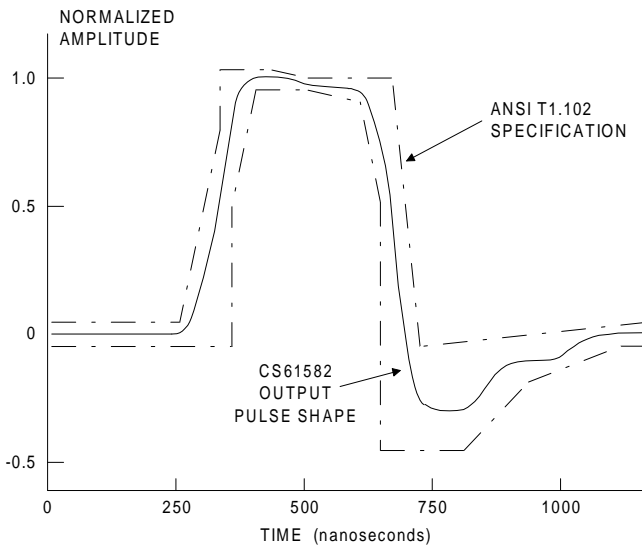
The transmitter accepts data from a T1 or E1 system and outputs pulses of appropriate shape to the line. The transmit clock (TCLK) and transmit data (TPOS and TNEG) are supplied synchronously. Data is sampled on the falling edge of the TCLK input.

The configuration pins CON[2:0] control transmitted pulse shapes, transmitter source impedance, and receiver slicing level as shown in Table 1. Typical output pulses are shown in Figures 5 and 6. These pulse shapes are fully pre-defined by circuitry in the CS61582, and are fully compliant with appropriate standards when used with our application guidelines in standard installations. Both channels must be operated at the same line rate (both T1 or both E1).

Note that the pulse width for Part 68 Option A (324 ns) is narrower than the optimal pulse width for DSX-1 (350 ns). The CS61582 auto-

<b>C O N 2</b>	<b>C O N 1</b>	<b>C O N 0</b>	<b>Transmit Pulse Width at 50% Amplitude</b>	<b>Transmit Pulse Shape</b>	<b>Receiver Slicing Level</b>
0	0	0	244 ns (50%)	E1: square, 2.37 Volts into 75 Ω	50%
0	0	1	244 ns (50%)	E1: square, 3.00 Volts into 120 Ω	50%
0	1	0	324 ns (50%)	DS1: FCC Part 68 Option A (0 dB)	65%
0	1	1	350 ns (54%)	DSX-1: 0-133 ft. / or DS1 FCC Part 68 Option A with undershoot	65%
1	0	0	350 ns (54%)	DSX-1: 133-266 ft.	65%
1	0	1	350 ns (54%)	DSX-1: 266-399 ft.	65%
1	1	0	350 ns (54%)	DSX-1: 399-533 ft.	65%
1	1	1	350 ns (54%)	DSX-1: 533-655 ft.	65%

**Table 1. Configuration Selection**



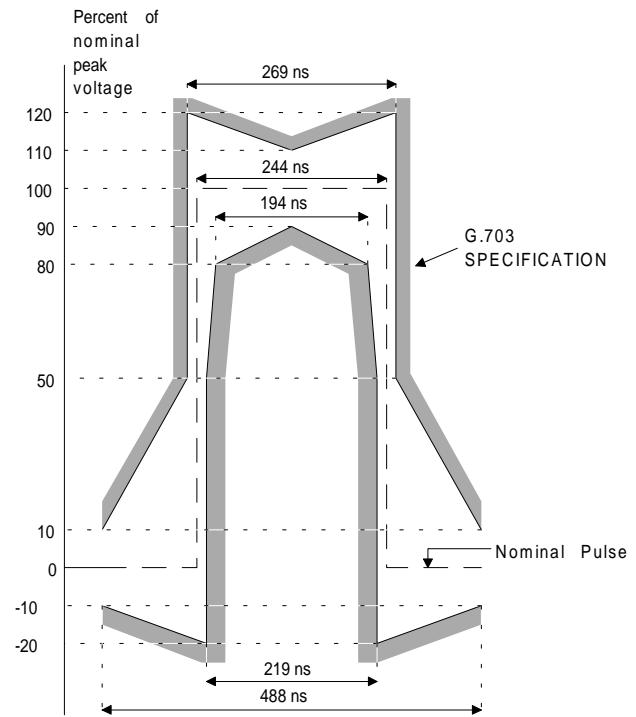
**Figure 5. Typical Pulse Shape at DSX-1 Cross Connect**

atically adjusts the pulse width based on the configuration selection.

The transmitter impedance changes with the line length options in order to match the load impedance (75Ω for E1 coax, 100Ω for T1, 120Ω for E1 shielded twisted pair), providing a minimum of 14 dB return loss for T1 and E1 frequencies during the transmission of both marks and spaces. This improves signal quality by minimizing reflections from the transmitter. Impedance matching also reduces load power consumption by a factor of two when compared to the return loss achieved by using external resistors.

The CS61582 driver will automatically detect an inactive TLCK input (i.e., no valid data is being clocked to the driver). When this condition is detected, the driver is forced low (except during remote loopback) to output spaces and prevent TTIP and TRING from entering a constant transmit-mark state.

When the transmit configuration established by CON[2:0], TAOS, or LLOOP changes state, the transmitter stabilizes within 22 TCLK bit periods. The transmitter takes longer to stabilize when RLOOP1 or RLOOP2 is selected because



**Figure 6. Pulse Mask at the 2048 kbps Interface**

the timing circuitry must adjust to the new frequency from RCLK.

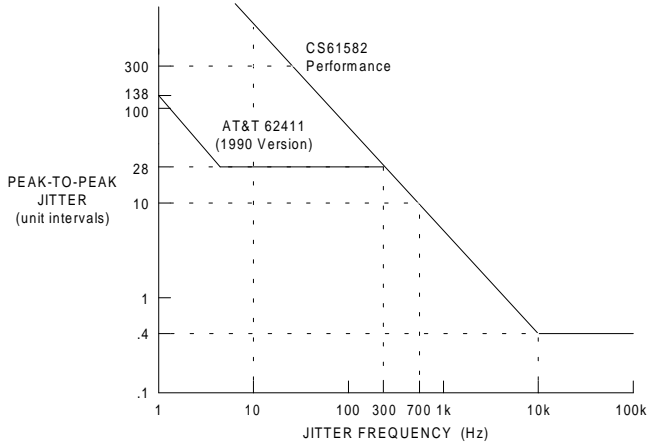
When the transmitter transformer secondaries are shorted through a 0.5 ohm resistor, the transmitter will output a maximum of 50 mA-rms, as required by European specification BS6450.

**RECEIVER**

The receiver extracts data and clock from the T1/E1 signal on the line interface and outputs clock and synchronized data to the system. The signal is detected differentially across the receive transformer and can be recovered over the entire range of short haul cable lengths. The transmit and receive transformer specifications are identical and are presented in the Applications section.

As shown in Table 1, the receiver slicing level is set at 65% for DS1/DSX-1 short-haul and at 50% for all other applications.

The clock recovery circuit is a second-order phase locked loop that can tolerate up to 0.4 UI of jitter from 10 kHz to 100 kHz without generating errors (Figure 7). The clock and data recovery circuit is tolerant of long strings of consecutive zeros and will successfully recover a 1-in-175 jitter-free line input signal.



**Figure 7. Minimum Input Jitter Tolerance of Receiver**

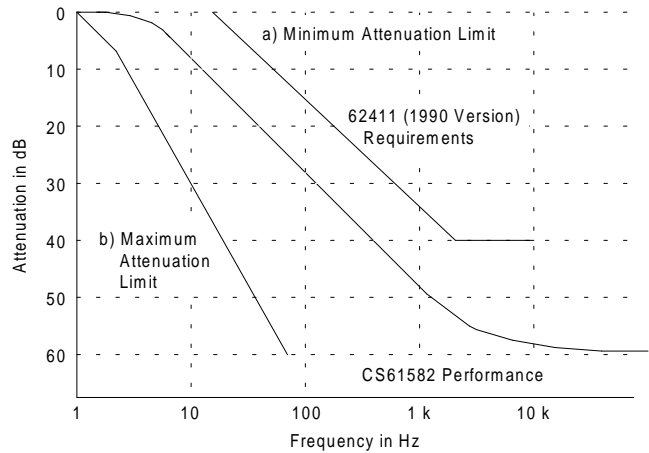
Recovered data at RPOS and RNEG is stable and may be sampled using the recovered clock RCLK. The CLKE input determines the clock polarity where the output data is stable and valid as shown in Table 2. When CLKE is low, RPOS and RNEG are valid on the rising edge of RCLK. When CLKE is high, RPOS and RNEG are valid on the falling edge of RCLK.

CLKE	DATA	CLOCK	Clock Edge for Valid Data
LOW	RPOS RNEG	RCLK RCLK	Rising Rising
HIGH	RPOS RNEG	RCLK RCLK	Falling Falling

**Table 2. Recovered Data/Clock Options**

**JITTER ATTENUATOR**

The jitter attenuator is located in the transmit path of each channel to remove gapped clock jitter on TCLK. Figure 8 illustrates the typical jitter attenuation curve.



**Figure 8. Typical Jitter Transfer Function**

The attenuator consists of a 64-bit FIFO, a narrow-band monolithic PLL, and control logic. Signal jitter is absorbed in the FIFO which is designed to neither overflow nor underflow. If overflow or underflow is imminent, the jitter transfer function is altered to insure that no bit-errors occur. Under this condition, jitter gain may occur and jitter should be attenuated externally in a frame buffer. The jitter attenuator will typically tolerate 43 UIs before the overflow/underflow mechanism occurs. If the jitter attenuator has not had time to "lock" to the average incoming frequency (e.g., following a device reset) the attenuator will tolerate a minimum of 22 UIs before the overflow/underflow mechanism occurs. The attenuator can accept a transmit clock with gaps  $\leq 28$  UIs and a transmit clock burst rate of  $\leq 8$  MHz.

When a loss of signal occurs, the last recovered frequency is not held and the output frequency becomes the frequency of the reference clock.

**REFERENCE CLOCK**

The CS61582 requires a reference clock with a minimum accuracy of  $\pm 100$  ppm for T1 and E1 applications. This clock can be either a 1X clock (i.e., 1.544 MHz or 2.048 MHz), or can be a 8X clock (i.e., 12.352 MHz or 16.384 MHz) as se-

lected by the 1XCLK pin. In systems with a jittered transmit clock, the reference clock should not be tied to the transmit clock and a separate external oscillator should drive the reference clock input. Any jitter present on the reference clock will not be filtered by the jitter attenuator.

## **POWER-UP RESET**

On power-up, the device is held in a static state until the power supply achieves approximately 60% of the power supply voltage. When this threshold is crossed, the device waits another 10 ms to allow the power supply to reach operating voltage and then calibrates the transmit and receive circuitry. This initial calibration takes less than 20 ms but can occur only if REFCLK and TCLK are present. The power-up reset performs the same functions as the RESET pin.

## **LINE CONTROL AND MONITORING**

Line control and monitoring of the CS61582 is achieved using the control pins. The controls and indications available on the CS61582 are detailed below.

### ***Device Performance Monitor***

To aid in the early detection and easy isolation of non-functioning links, the CS61582 is capable of monitoring the transmit driver performance and report when the driver is no longer operational. The driver performance monitor consists of an activity detector that monitors the transmitted signal when MTIP is connected to TTIP and MRING is connected to TRING. The DPM output will go high when the differential inputs MTIP and MRING are inactive for  $512 \pm 2$  REFCLK periods. The DPM output returns low when the monitor senses a minimum 12.5% ones density signal over  $175 \pm 75$  bit periods with no more than 100 consecutive zeros. To increase the reliability of the performance monitor, it is suggested that the monitor inputs of one channel be

connected the transmitter output pins of another channel or device.

### ***Loss of Signal***

The loss of signal (LOS) indication is detected by the receiver and reported by setting the LOS pin high. Loss of signal is indicated when  $175 \pm 15$  consecutive zeros are received. The LOS condition is exited according to the ANSI T1.231-1993 criteria that requires 12.5% ones density over  $175 \pm 75$  bit periods with no more than 100 consecutive zeros. Note that bit errors may occur at RPOS and RNEG prior to the LOS indication if the analog input level falls below the receiver sensitivity.

The LOS pin is set high when the device is reset or in power-up and returns low when data is recovered by the receiver.

### ***Transmit All Ones***

Transmit all ones is selected by setting the TAOS pin high. Selecting TAOS causes continuous ones to be transmitted to the line interface on TTIP and TRING at the frequency of REFCLK. In this mode, the transmit data inputs TPOS and TNEG are ignored. A TAOS request overrides the data transmitted to the line interface during local and remote loopbacks.

### ***Local Loopback***

A local loopback is selected by setting the LLOOP pin high. Selecting LLOOP causes the TCLK, TPOS, and TNEG inputs to be looped back through the jitter attenuator to the RCLK, RPOS, and RNEG outputs. Data received at the line interface is ignored, but data at TPOS and TNEG continues to be transmitted to the line interface at TTIP and TRING.

A TAOS request overrides the data transmitted to the line interface during local loopback. Note that simultaneous selection of local and remote loopback modes is not valid.

**Remote Loopback**

A remote loopback is selected by setting the RLOOP pin high. Selecting RLOOP causes the data received from the line interface at RTIP and RRING to be looped back through the jitter attenuator and retransmitted on TTIP and TRING. Data transmitted at TPOS and TNEG is ignored, but data recovered from RTIP and RRING continues to be transmitted on RPOS and RNEG.

Remote loopback is functional if TCLK is absent. A TAOS request overrides the data transmitted to the line interface during a remote loopback. Note that simultaneous selection of local and remote loopback modes is not valid.

**Reset Pin**

The CS61582 is continuously calibrated during operation to insure the performance of the device over power supply and temperature. This continuous calibration function eliminates the need to reset the line interface during operation.

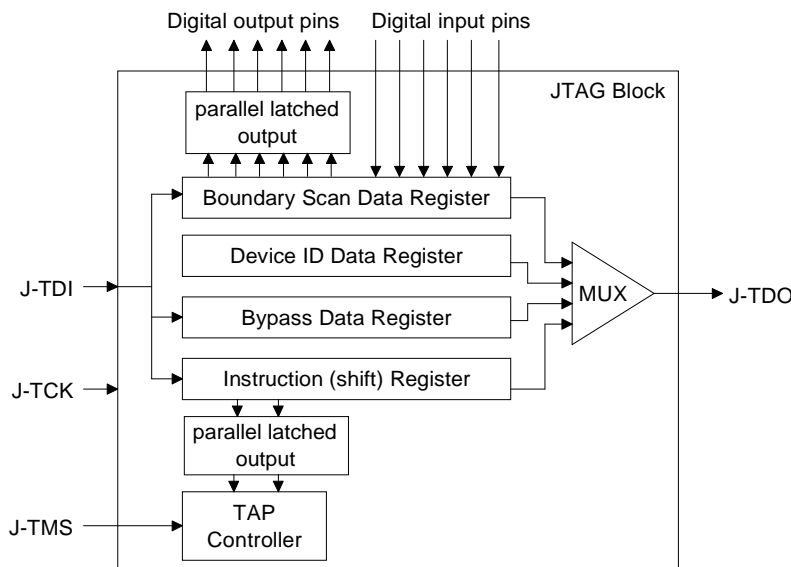
A device reset may be selected by setting the RESET pin high for a minimum of 200 ns. The reset function initiates on the falling edge of RESET and requires less than 20 ms to complete. The control logic is initialized and the transmit

and receive circuitry is calibrated if REFCLK and TCLK are present.

**JTAG BOUNDARY SCAN**

Board testing is supported through JTAG boundary scan. Using boundary scan, the integrity of the digital paths between devices on a circuit board can be verified. This verification is supported by the ability to externally set the signals on the digital output pins of the CS61582, and to externally read the signals present on the input pins of the CS61582. Additionally, the manufacturer ID, part number and revision of the CS61582 can be read during board test using JTAG boundary scan.

As shown in Figure 9, the JTAG hardware consists of data and instruction registers plus a Test Access Port (TAP) controller. Control of the TAP is achieved through signals applied to the Test Mode Select (J-TMS) and Test Clock (J-TCK) input pins. Data is shifted into the registers via the Test Data Input (J-TDI) pin, and shifted out of the registers via the Test Data Output (J-TDO) pin. Both J-TDI and J-TDO are clocked at a rate determined by J-TCK. The Instruction register defines which data register is accessed in the



**Figure 9. Block Diagram of JTAG Circuitry**

shift operation. Note that if J-TDI is floating, an internal pull-up resistor forces the pin high.

### JTAG Data Registers (DR)

The test data registers are the Boundary-Scan Register (BSR), the Device Identification Register (DIR), and the Bypass Register (BR).

BSR bits	Pin Name	Pad Type
0-2	LOS1	bi-directional <sup>2</sup>
3-5	TNEG1	bi-directional <sup>1</sup>
6	TPOS1	input
7	TCLK1	input
8-9	RNEG1	output
10-11	RPOS1	output
12-13	RCLK1	output
14-16	DPM1	bi-directional <sup>2</sup>
17-19	RLOOP1	bi-directional <sup>1</sup>
20	LLOOP2	input
21-23	LLOOP1	bi-directional <sup>1</sup>
24-26	TAOS1	bi-directional <sup>1</sup>
27-29	TAOS2	bi-directional <sup>1</sup>
30-32	CON01	bi-directional <sup>1</sup>
33-35	CON02	bi-directional <sup>1</sup>
36-38	CON11	bi-directional <sup>1</sup>
39-41	CON12	bi-directional <sup>1</sup>
42-44	CON21	bi-directional <sup>1</sup>
45	CON22	input
46-48	DPM2	bi-directional <sup>2</sup>
49-50	RCLK2	output
51-52	RPOS2	output
53-54	RNEG2	output
55	TCLK2	input
56	TPOS2	input
57-59	TNEG2	bi-directional <sup>1</sup>
60-62	LOS2	bi-directional <sup>2</sup>
63	CLKE	input
64	RLOOP2	input

1. Configure pad as an input.
2. Configure pad as an output.

**Table 3. Boundary Scan Register**

**Boundary Scan Register:** The BSR is connected in parallel to all the digital I/O pins, and provides the mechanism for applying/reading test patterns to/from the board traces. The BSR is 65 bits long and is initialized and read using the instruction SAMPLE/PRELOAD. The bit ordering for the BSR is the same as the top-view package pin out, beginning with the LOS1 pin and moving counter-clockwise to end with the RLOOP2 pin as shown in Table 3.

The input pins require one bit in the BSR and only one J-TCK cycle is required to load test data for each input pin.

The output pins have two bits in the BSR to define output high, output low, or high impedance. The first bit (shifted in first) selects between an output-enabled state (bit set to 1) or high-impedance state (bit set to 0). The second bit shifted in contains the test data that may be output on the pin. Therefore, two J-TCK cycles are required to load test data for each output pin.

The bi-directional pins have three bits in the BSR to define input, output high, output low, or high impedance. The first bit shifted into the BSR configures the output driver as high-impedance (bit set to 0) or active (bit set to 1). The second bit shifted into the BSR sets the output value when the first bit is 1. The third bit captures the value of the pin. This pin may have its value set externally as an input (if the first bit is 0) or set internally as an output (if the first bit is 1). To configure a pad as an input, the J-TDI pattern is 0X0. To configure a pad as an output, the J-TDI pattern is 1X1. Therefore, three J-TCK cycles are required to load test data for each bi-directional pin.

**Device Identification Register:** The DIR provides the manufacturer, part number, and version of the CS61582. This information can be used to verify that the proper version or revision number has been used in the system under test. The DIR is 32 bits long and is partitioned as shown in figure 10.



registers. The value shown next to each state transition in this figure is the value present at J-TMS at each rising edge of J-TCK.

**Test-Logic-Reset State**

In this state, the test logic is disabled to continue normal operation of the device. During initialization, the CS61582 initializes the instruction register with the IDCODE instruction.

Regardless of the original state of the controller, the controller enters the Test-Logic-Reset state when the J-TMS input is held high for at least five rising edges of J-TCK. The controller remains in this state while J-TMS is high. The CS61582 processor automatically enters this state at power-up.

**Run-Test/Idle State**

This is a controller state between scan operations. Once in this state, the controller remains in the state as long as J-TMS is held low. The instruction register and all test data registers retain their previous state. When J-TMS is high and a rising edge is applied to J-TCK, the controller moves to the Select-DR state.

**Select-DR-Scan State**

This is a temporary controller state. The test data register selected by the current instruction retains its previous state. If J-TMS is held low and a rising edge is applied to J-TCK when in this state, the controller moves into the Capture-DR state and a scan sequence for the selected test data register is initiated. If J-TMS is held high and a rising edge applied to J-TCK, the controller moves to the Select-IR-Scan state.

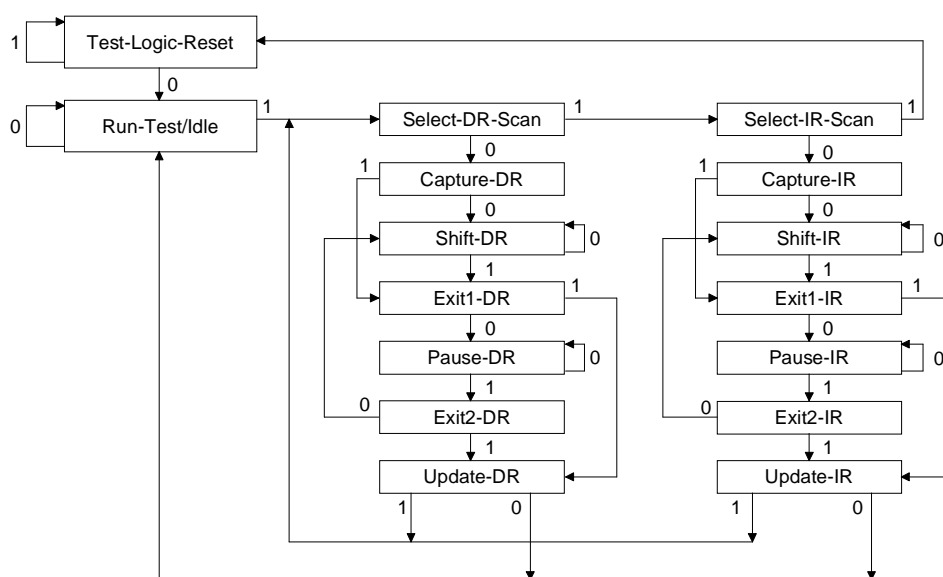
The instruction does not change in this state.

**Capture-DR State**

In this state, the Boundary Scan Register captures input pin data if the current instruction is EXTEST or SAMPLE/PRELOAD. The other test data registers, which do not have parallel input, are not changed.

The instruction does not change in this state.

When the TAP controller is in this state and a rising edge is applied to J-TCK, the controller enters the Exit1-DR state if J-TMS is high or the Shift-DR state if J-TMS is low.



**Figure 11. TAP Controller State Diagram**



### ***Shift-DR State***

In this controller state, the test data register connected between J-TDI and J-TDO as a result of the current instruction shifts data on stage toward its serial output on each rising edge of J-TCK.

The instruction does not change in this state.

When the TAP controller is in this state and a rising edge is applied to J-TCK, the controller enters the Exit1-DR state if J-TMS is high or remains in the Shift-DR state if J-TMS is low.

### ***Exit1-DR State***

This is a temporary state. While in this state, if J-TMS is held high, a rising edge applied to J-TCK causes the controller to enter the Update-DR state, which terminates the scanning process. If J-TMS is held low and a rising edge is applied to J-TCK, the controller enters the Pause-DR state.

The test data register selected by the current instruction retains its previous value during this state. The instruction does not change in this state.

### ***Pause-DR State***

The pause state allows the test controller to temporarily halt the shifting of data through the test data register in the serial path between J-TDI and J-TDO. For example, this state could be used to allow the tester to reload its pin memory from disk during application of a long test sequence.

The test data register selected by the current instruction retains its previous value during this state. The instruction does not change in this state.

The controller remains in this state as long as J-TMS is low. When J-TMS goes high and a rising edge is applied to J-TCK, the controller moves to the Exit2-DR state.

### ***Exit2-DR State***

This is a temporary state. While in this state, if J-TMS is held high, a rising edge applied to J-TCK causes the controller to enter the Update-DR state, which terminates the scanning process. If J-TMS is held low and a rising edge is applied to J-TCK, the controller enters the Shift-DR state.

The test data register selected by the current instruction retains its previous value during this state. The instruction does not change in this state.

### ***Update-DR State***

The Boundary Scan Register is provided with a latched parallel output to prevent changes while data is shifted in response to the EXTEST and SAMPLE/PRELOAD instructions. When the TAP controller is in this state and the Boundary Scan Register is selected, data is latched into the parallel output of this register from the shift-register path on the falling edge of J-TCK. The data held at the latched parallel output changes only in this state.

All shift-register stages in the test data register selected by the current instruction retains their previous value during this state. The instructions does not change in this state.

### ***Select-IR-Scan State***

This is a temporary controller state. The test data register selected by the current instruction retains its previous state. If J-TMS is held low and a rising edge is applied to J-TCK when in this state, the controller moves into the Capture-IR state, and a scan sequence for the instruction register is initiated. If J-TMS is held high and a rising edge is applied to J-TCK, the controller moves to the Test-Logic-Reset state. The instruction does not change in this state.

### ***Capture-IR State***

In this controller state, the shift register contained in the instruction register loads a fixed value of "01" on the rising edge of J-TCK. This supports fault-isolation of the board-level serial test data path.

Data registers selected by the current instruction retain their value during this state. The instructions does not change in this state.

When the controller is in this state and a rising edge is applied to J-TCK, the controller enters the Exit1-IR state if J-TMS is held high, or the Shift-IR state if J-TMS is held low.

### ***Shift-IR State***

In this state, the shift register contained in the instruction register is connected between J-TDI and J-TDO and shifts data one stage towards its serial output on each rising edge of J-TCK.

The test data register selected by the current instruction retains its previous value during this state. The instruction does not change in this state.

When the controller is in this state and a rising edge is applied to J-TCK, the controller enters the Exit1-IR state if J-TMS is held high, or remains in the Shift-IR state if J-TMS is held low.

### ***Exit1-IR State***

This is a temporary state. While in this state, if J-TMS is held high, a rising edge applied to J-TCK causes the controller to enter the Update-IR state, which terminates the scanning process. If J-TMS is held low and a rising edge is applied to J-TCK, the controller enters the Pause-IR state.

The test data register selected by the current instruction retains its previous value during this state. The instruction does not change in this state.

### ***Pause-IR State***

The pause state allows the test controller to temporarily halt the shifting of data through the instruction register.

The test data register selected by the current instruction retains its previous value during this state. The instruction does not change in this state.

The controller remains in this state as long as J-TMS is low. When J-TMS goes high and a rising edge is applied to J-TCK, the controller moves to the Exit2-IR state.

### ***Exit2-IR State***

This is a temporary state. While in this state, if J-TMS is held high, a rising edge applied to J-TCK causes the controller to enter the Update-IR state, which terminates the scanning process. If J-TMS is held low and a rising edge is applied to J-TCK, the controller enters the Shift-IR state.

The test data register selected by the current instruction retains its previous value during this state. The instruction does not change in this state.

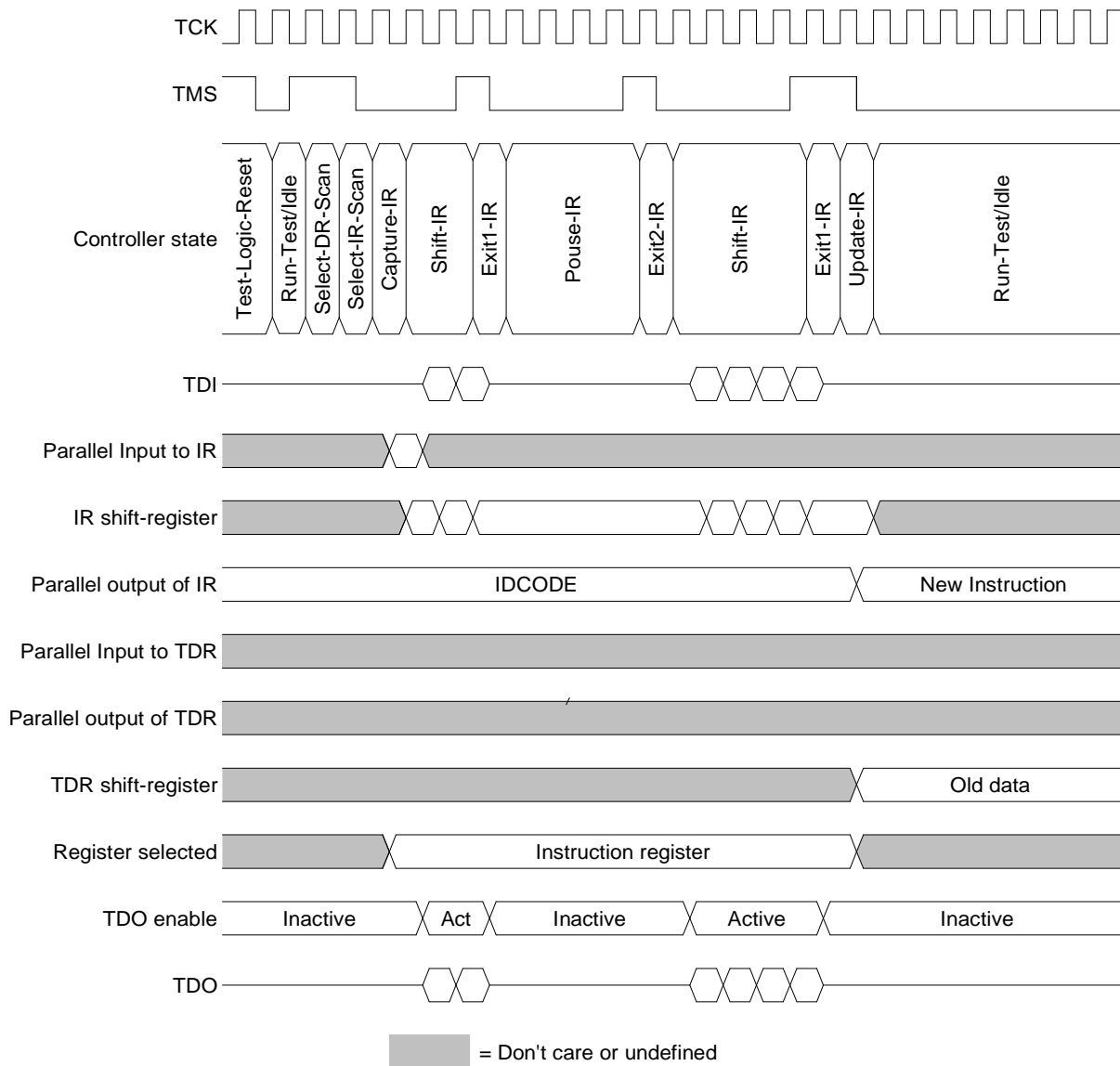
### ***Update-IR State***

The instruction shifted into the instruction register is latched into the parallel output from the shift-register path on the falling edge of J-TCK. When the new instruction has been latched, it becomes the current instruction.

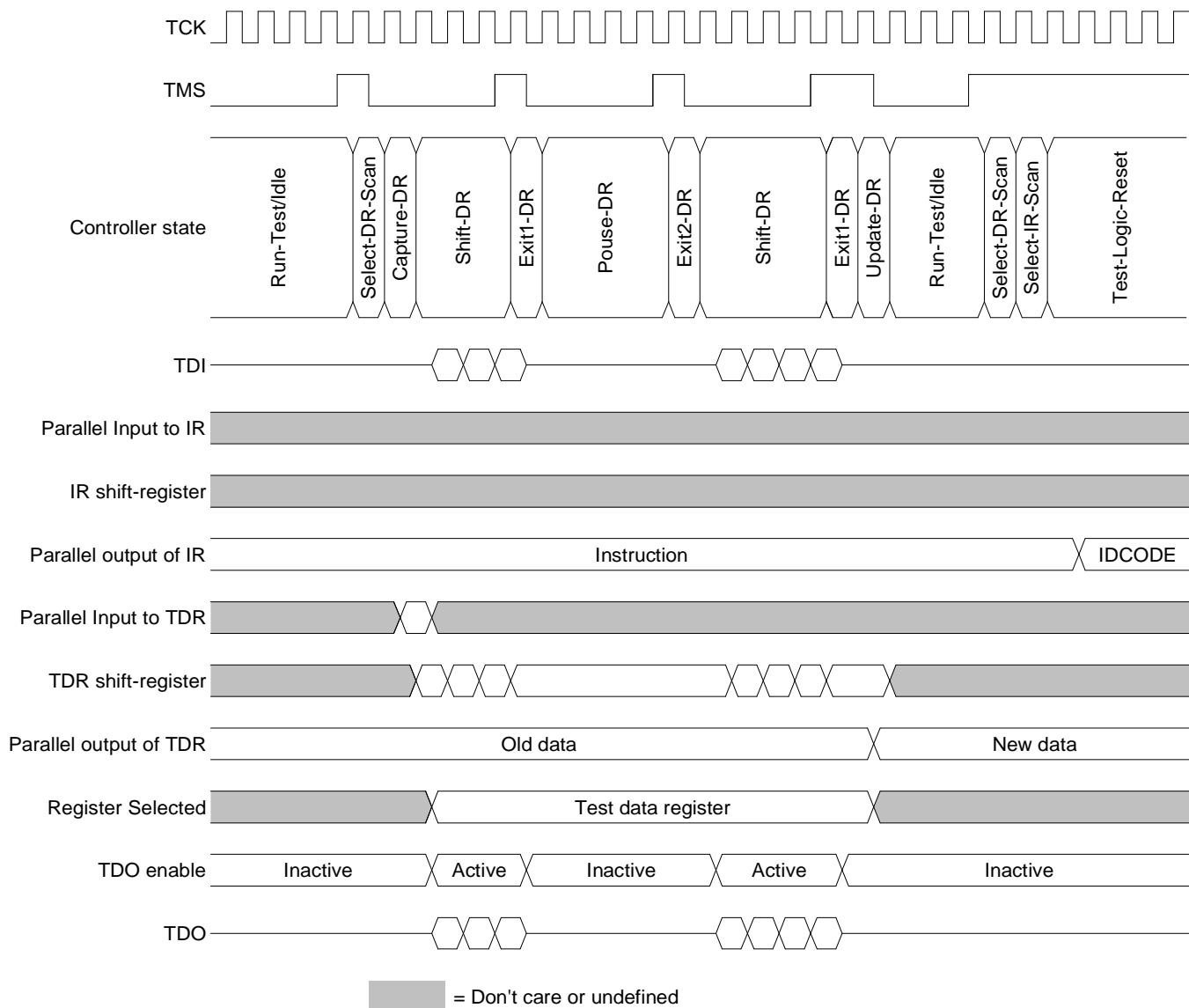
Test data registers selected by the current instruction retain their previous value.

### ***JTAG Application Examples***

Figures 12 and 13 illustrate examples of updating the instruction and data registers during JTAG operation.

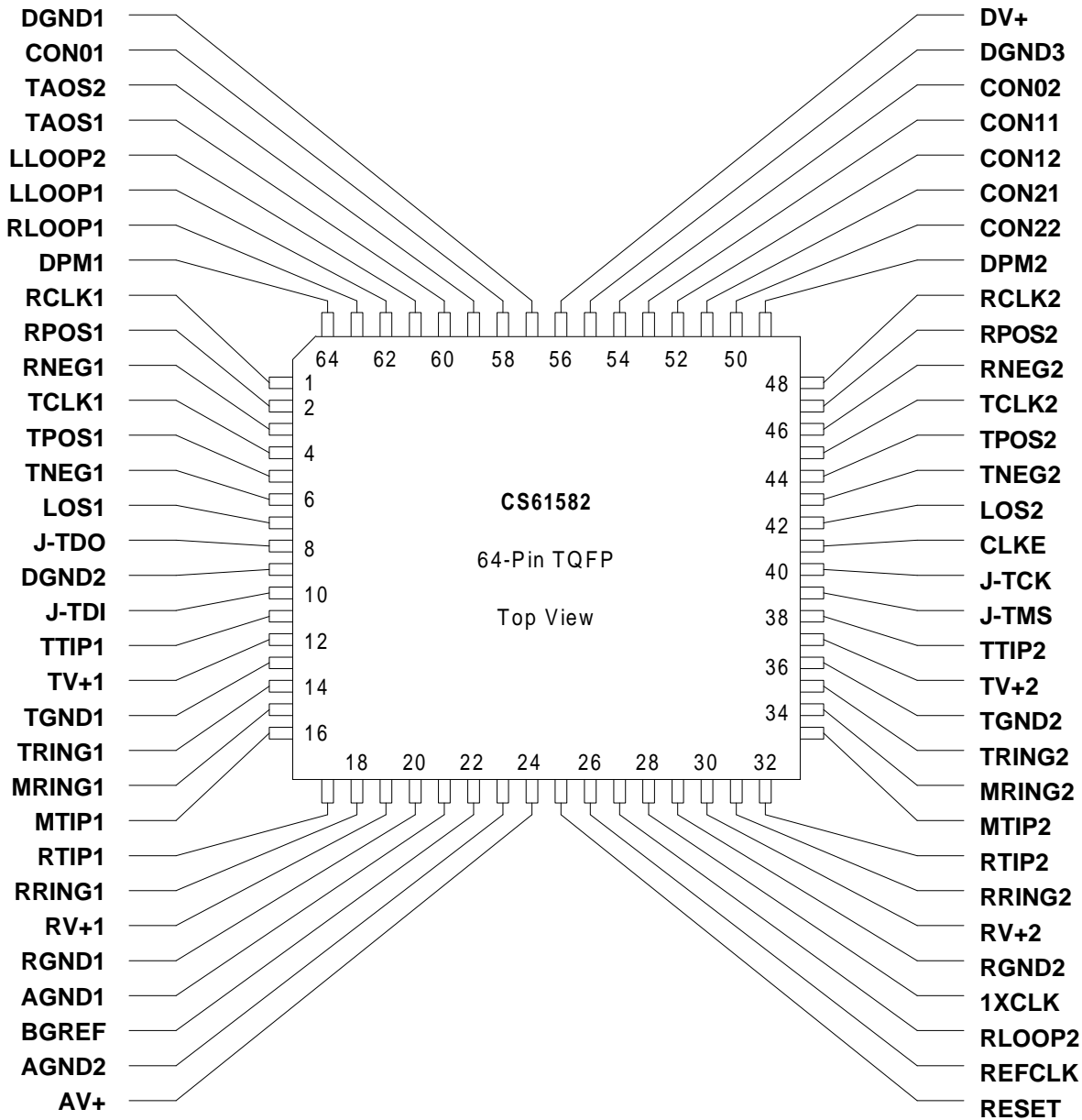


**Figure 12. JTAG Instruction Register Update**



**Figure 13. JTAG Data Register Update**

**PIN DESCRIPTIONS**



**Power Supplies****AGND1, AGND2 : Analog Ground (Pins 21, 23)**

Analog supply ground pins.

**AV+ : Analog Power Supply (Pin 24)**

Analog supply pin for the internal bandgap reference and timing generation circuits.

**BGREF : Bandgap Reference (Pin 22)**

This pin is used by the internal bandgap reference and must be connected to ground by a  $4.99\text{k}\Omega \pm 1\%$  resistor to provide an internal current reference.

**DGND1, DGND2, DGND3 : Digital Ground (Pins 57, 9, 55)**

Power supply ground pins for the digital circuitry of both channels.

**DV+ : Power Supply (Pin 56)**

Power supply pin for the digital circuitry of both channels.

**RGND1, RGND2 : Receiver Ground (Pins 20, 29)**

Power supply ground pins for the receiver circuitry.

**RV+1, RV+2 : Receiver Power Supply (Pins 19, 30)**

Power supply pins for the analog receiver circuitry.

**TGND1, TGND2 : Transmit Ground (Pins 13, 36)**

Power supply ground pins for the transmitter circuitry.

**TV+1, TV+2 : Transmit Power Supply (Pins 12, 37)**

Power supply pins for the analog transmitter circuitry.

**TI/EI Data****RCLK1, RCLK2 : Receive Clock (Pins 1, 48)****RPOS1, RPOS2 : Receive Positive Data (Pins 2, 47)****RNEG1, RNEG2 : Receive Negative Data (Pins 3, 46)**

The receiver recovered clock and NRZ digital data from RTIP and RRING is output on these pins. The CLKE pin determines the clock edge on which RPOS and RNEG are stable and valid as shown in Table 2. A positive pulse (with respect to ground) received on RTIP generates a logic 1 on RPOS, and a positive pulse received on RRING generates a logic 1 on RNEG.

**RTIP1, RTIP2 : Receive Tip (Pins 17, 32)****RRING1, RRING2 : Receive Ring (Pins 18, 31)**

The receive AMI signal from the line interface is input on these pins. The recovered clock and data are output on RCLK, RPOS, and RNEG.

**TTIP1, TTIP2 : Transmit Tip (Pins 11, 38)****TRING1, TRING2 : Transmit Ring (Pins 14, 35)**

The transmit AMI signal to the line interface is output on these pins. The transmit clock and data are input from TCLK, TPOS, and TNEG.

**TCLK1, TCLK2 : Transmit Clock (Pins 4, 45)****TPOS1, TPOS2 : Transmit Positive Data (Pins 5, 44)****TNEG1, TNEG2 : Transmit Negative Data (Pins 6, 43)**

The transmit clock and data are input on these pins. The signal is driven to the line at TTIP and TRING. Data on TPOS and TNEG are sampled on the falling edge of TCLK. An input on TPOS causes a positive pulse to be transmitted at TTIP and TRING, while an input on TNEG input causes a negative pulse to be transmitted at TTIP and TRING.

**Oscillator****1XCLK : One-times Clock Frequency Select (Pin 28)**

When 1XCLK is set high, REFCLK must be a 1X clock (i.e., 1.544 MHz for T1 applications or 2.048 MHz for E1 applications). When 1XCLK is set low, REFCLK must be an 8X clock (i.e., 12.352 MHz for T1 applications or 16.384 MHz for E1 applications).

**REFCLK : External Reference Clock Input (Pin 26)**

Input reference clock for the receive and jitter attenuator circuits. When 1XCLK is set high, REFCLK must be a 1X clock (i.e., 1.544 MHz  $\pm$ 100 ppm for T1 applications or 2.048 MHz  $\pm$ 100 ppm for E1 applications). When 1XCLK is set low, REFCLK must be an 8X clock (i.e., 12.352 MHz  $\pm$ 100 ppm for T1 applications or 16.384 MHz  $\pm$ 100 ppm for E1 applications). The REFCLK input also determines the transmission rate when TAOS is asserted.

**Control****CLKE : Clock Edge (Pin 41)**

Controls the polarity of the recovered clock RCLK. When CLKE is high, RPOS and RNEG are valid on the falling edge of RCLK. When CLKE is low, RPOS and RNEG are valid on the rising edge of RCLK.

**CON01, CON11, CON21 : Configuration for Channel 1 (Pins 58, 53, 51)****CON02, CON12, CON22 : Configuration for Channel 2 (Pins 54, 52, 50)**

These pins configure the transmitter (pulse shape, pulse width, pulse amplitude, and driver impedance) and receiver (slicing level). The CONx1 pins control channel 1 and the CONx2 pins control channel 2. Both channels must be configured to operate at the same data rate on the line interface (both T1 or both E1).

**LLOOP1, LLOOP2 : Local Loopback (Pins 62, 61)**

A local loopback is enabled when LLOOP is high. During local loopback, the TCLK, TPOS, and TNEG inputs are looped back through the jitter attenuator to the RCLK, RPOS, and RNEG outputs. The data at TPOS and TNEG continues to be transmitted to the line interface unless overridden by a TAOS request. The inputs at RTIP and RRING are ignored.

**RESET : Reset (Pin 25)**

A device reset is selected by setting the RESET pin high for a minimum of 200 ns. The reset function initiates on the falling edge of RESET and requires less than 20 ms to complete. The control logic is initialized and LOS is set high.

**RLOOP1, RLOOP2 : Remote Loopback (Pins 63, 27)**

A remote loopback is selected when RLOOP is high. The data received from the line interface at RTIP and RRING is looped back through the jitter attenuator and retransmitted on TTIP and TRING. Data recovered from RTIP and RRING continues to be transmitted on RPOS and RNEG. Data input on TPOS and TNEG is ignored. A TAOS request overrides the data transmitted at TTIP and TRING.

**TAOS1, TAOS2 : Transmit All Ones Select (Pins 60, 59)**

Setting TAOS high causes continuous ones to be transmitted at the line interface on TTIP and TRING at the frequency determined by REFCLK.

***Status*****DPM1, DPM2 : Driver Performance Monitor Alarm (Pins 64, 49)**

The DPM alarm indication goes high when differential inputs MTIP and MRING are inactive for  $512 \pm 2$  REFCLK periods. The DPM alarm indication returns low when MTIP and MRING detect a minimum 12.5% ones density signal over  $175 \pm 75$  bit periods with no more than 100 consecutive zeros.

**MTIP1, MTIP2 : Monitor Tip (Pins 16, 33)****MRING1, MRING2 : Monitor Ring (Pins 15, 34)**

The MTIP and MRING inputs may be connected to TTIP and TRING, to detect an inactive transmit driver. The MTIP and MRING inputs are differential and may be connected to either transmitter output. To increase the reliability of the performance monitor, it is suggested that the monitor inputs of one channel be connected the transmitter output pins of another channel or device.

**LOS1, LOS2 : Loss of Signal (Pins 7, 42)**

The LOS indication goes high when  $175 \pm 15$  consecutive zeros are received on the line interface. The LOS indication returns low when a minimum 12.5% ones density signal over  $175 \pm 75$  bit periods with no more than 100 consecutive zeros is received.

***Test*****J-TCK : JTAG Test Clock (Pin 40)**

Data on pins J-TDI and J-TDO is valid on the rising edge of J-TCK. When J-TCK is stopped low, all JTAG registers remain unchanged.

**J-TMS : JTAG Test Mode Select (Pin 39)**

An active high signal on J-TMS enables the JTAG serial port. This pin has an internal pull-up resistor.

**J-TDI : JTAG Test Data In (Pin 10)**

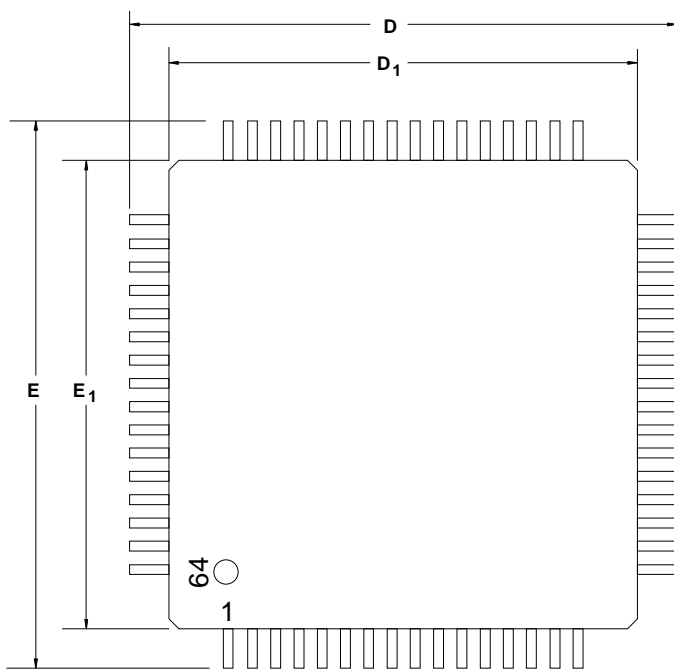
JTAG data is shifted into the device on this pin. This pin has an internal pull-up resistor. Data must be stable on the rising edge of J-TCK.

**J-TDO : JTAG Test Data Out (Pin 8)**

JTAG data is shifted out of the device on this pin. This pin is active only when JTAG testing is in progress. J-TDO will be updated on the falling edge of J-TCK.

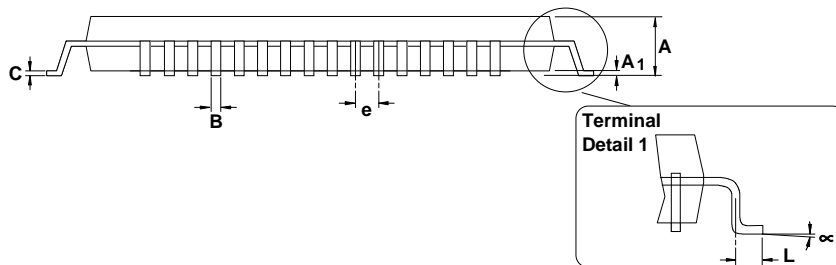


PHYSICAL DIMENSIONS

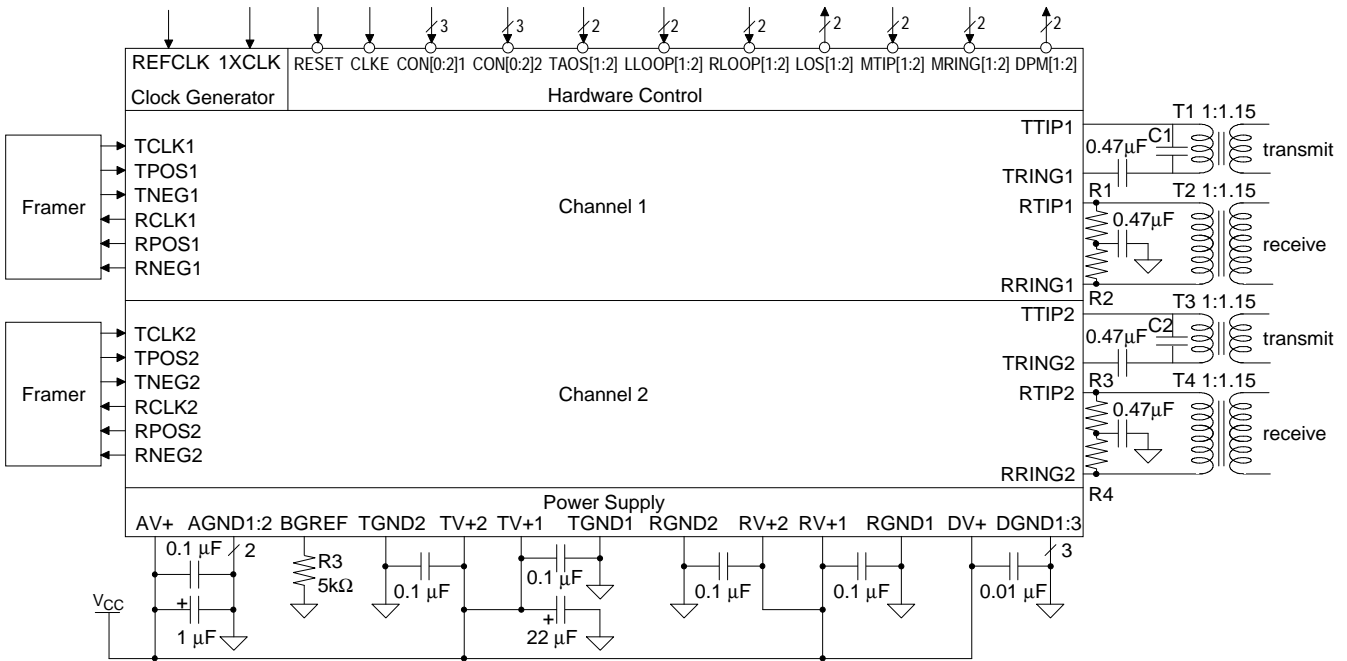


**64-Pin  
TQFP**

DIM	MILLIMETERS		INCHES	
	MIN	MAX	MIN	MAX
A	-	1.66	-	0.068
A1	0.00	-	0.00	-
B	0.14	0.26	0.006	0.010
C	0.077	0.177	0.003	0.007
D	11.70	12.30	0.461	0.484
D1	10.00	10.00	0.394	0.394
E	11.70	12.30	0.461	0.484
E1	10.00	10.00	0.394	0.394
e	0.40	0.60	0.016	0.024
L	0.35	0.70	0.014	0.028
$\alpha$	0°	12°	0°	12°



**APPLICATIONS**



**Figure A1. Typical Connection Diagram**

Data Rate (MHz)	REFCLK Frequency (MHz)		Cable (Ω)	R1-R4 (Ω)	C1-C2 (pF)
	1XCLK = 1	1XCLK = 0			
1.544	1.544	12.352	100	38.3	220
2.048	2.048	16.384	75	28.7	470
			120	45.3	220

**Table A1. CS61582 External Components**

**Line Interface**

Figure A1 illustrates a typical connection diagram and Table A1 lists the external components that are required in T1 and E1 applications.

In the transmit line interface circuitry, capacitors C1 and C2 provide transmitter return loss. The 0.47 μF capacitor in series with the transformer primary prevents output stage imbalances from producing a DC current through the transformer that might saturate the transformer and result in an output level offset.

In the receive line interface circuitry, resistors R1-R4 provide receive impedance matching and receiver return loss. The 0.47 μF capacitor to ground provides the necessary differential input voltage reference for the receiver.

**Power Supply**

As shown in Figure A1, the CS61582 operates from a 5.0 Volt supply. Separate analog and digital power supply and ground pins provide internal isolation. The TGND, RGND, and DGND ground pins must not be more negative than AGND. It is recommended that all of the supply pins be con-

nected together at the device. A  $4.99k\Omega \pm 1\%$  resistor must be connected from BGREF to ground to provide an internal current reference.

De-coupling and filtering of the power supplies is crucial for the proper operation of the analog circuits. A capacitor should be connected between each supply and its respective ground. For capacitors smaller than  $1 \mu\text{F}$ , use mylar or ceramic capacitors and place them as close as possible to their respective power supply pins. Wire-wrap bread boarding of the line interface is not recommended because lead resistance and inductance defeat the function of the de-coupling capacitors.

### Crystal Oscillator

When a reference clock signal is not available, a CMOS crystal oscillator operating at either the 1X or 8X rate can be connected at the REFCLK pin. The oscillator must have a minimum symmetry of 40-60% and minimum stability of  $\pm 100$  ppm for T1 and E1 applications. Based on these specifications, some suggested crystal oscillators for use with the CS61582 are shown in Table A2.

Manufacturer	Part Number	Contact Number
Comclok	CT31CH	(800) 333-9825
CTS	CXO-65HG-5-I	(815) 786-8411
M-tron	MH26TAD	(800) 762-8800
SaRonix	NTH250A	(800) 227-8974

Notes:

Frequency tolerances are  $\pm 32$  ppm with a  $-40$  to  $+85$  °C operating temperature range.

All are 8-pin DIP packages and can be tristated.

**Table A2. Suggested Crystal Oscillators**

### Transformers

Recommended transformer specifications are shown in Table A3. Based on these specifications, the transformers recommended for use with the CS61582 are listed in Table A4.

Turns ratio	1:1.15 step-up transmit 1:1.15 step-down receive
Primary inductance	1.5 mH min at 772 kHz
Primary leakage inductance	0.3 $\mu\text{H}$ max at 772 kHz with secondary shorted
Secondary leakage inductance	0.4 $\mu\text{H}$ max at 772 kHz
Interwinding capacitance	18 pF max, primary to secondary
ET-constant	16 V- $\mu\text{s}$ min

**Table A3. Transformer Specifications**

### Line Protection

Secondary protection components can be added to the line interface circuitry to provide lightning surge and AC power-cross immunity. For additional information on the different electrical safety standards and specific application circuit recommendations, refer to the Crystal Semiconductor Application Note "Secondary Line Protection for T1 and E1 Line Cards."

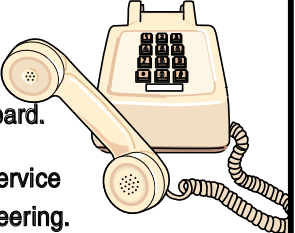
Turns Ratio	Manufacturer	Part Number	Package Type
1:1.15	Pulse Engineering	PE-65388	1.5 kV through-hole, single
		PE-65770	1.5 kV through-hole, single extended temperature
		PE-65838	3.0 kV through-hole, single extended temperature
		PE-68674	1.5 kV surface-mount, dual extended temperature
		PE-65870	1.5 kV surface-mount, dual
	Schott	67124840	1.5 kV through-hole, single extended temperature
	Valor	ST5112	2.0 kV surface mount, dual

**Table A4. Recommended Transformers**

### Schematic & Layout Review Service

Confirm Optimum  
Schematic & Layout  
Before Building Your Board.

For Our Free Review Service  
Call Applications Engineering.



**C a l l : ( 5 1 2 ) 4 4 5 - 7 2 2 2**

• **Notes** •

---

• **Notes** •

• **Notes** •



Smart *Analog*<sup>TM</sup> is a Trademark of Crystal Semiconductor Corporation